



The Remarkable Technology Co.,Ltd

China number:+86-21-20961227
US Number:+1 813 327 3872
<http://www.remarkable-investment.com/>

OFFICE: 9TH Floor , A8 Building , No. 2555 Xiupu Road , Pudong , S.H.CN.
Factory address: No.7228, Daye Road,Fengxian , S.H.CN.
US Warehouse: 88 Clyde Alexander Way, Pooler GA 31322



Scan
to Know us





The Remarkable Technology Company
A packaging solution provider for Sports Nutrition,
Nutraceutical, Health, Wellness, Food and Beverage

COMPANY PROFILE

The Remarkable Technology Co.,Ltd
"Your One Stop Source Packaging solution Provider"

RTCO is a leading one stop source for customized packaging solutions for the Health and Beauty, Sports Nutrition, and Supplement industries.

We have built our reputation by developing innovative, high end packaging for these segments, providing brand specific, and identifiable packaging that makes your product stand above all of your competition.

In 2009, we successfully integrated our patented SGP and SAP technology by combining the traditional process of vacuum metallization and soft touch, to the outer layer coating on both HDPE and PET. This customization can be applied to all types of jars and bottles. We can also complete your custom package, by adding the closure with the same beautiful finish.

We have made available, a series of creatives options of customization...in addition to the gold and silver metallized, as well as our gun metal gray, we can do virtually any color in the rainbow, even a spectacular pearled translucent finish that catches every eye! And if that wasn't enough, we have our top selling soft touch coating. This too can be any color, and can be applied to most bottles and cannisters, turning ordinary stock white or black jars and bottles, into singular, one of a kind packaging!

Our customers have experienced dramatic growth and brand recognition BY using our patented process, writing new and exciting success stories!

Collaboratively with our global customer base, we have been continuously improving our products, and developing customized innovation. We have successfully developed the technology of SAB and SAH to effectively solve issues including; bottle paneling or "imploding", out of round issues, "powder caking", and premature product failure and loss of efficacy. Our proprietary solution solves the problem of air pressure, as well as temperature and humidity issues that are present in some geographic areas.

Beginning in early 2024, **RTCO** will open a new sales and distribution warehouse in the USA! Maintaining stock and custom items for "Just In Time" fulfillment and delivery.

We look forward to the opportunity to explore your needs, and show how we can be a strategic packaging solutions partner. Our goal is to create a long term, mutually beneficial relationship...growing both of our companies as we move into the future!

Our team is excited to connect with you, and show how **RTCO** can take your company from great, to GREATEST!

RTCO

Remarkable Technology



PRODUCT CONTENTS

◆ Breathable Liner	01
◆ Biodegradable	03
◆ Scoophook	05
◆ PES	07
◆ RC004 Softtouch Canister	09
◆ RC001 Chrome Canister	
◆ RC008 Plain Canister	
◆ RC008 Big Gallon Bottlr	11
◆ RTCO Powder PP Cap	12
◆ RC008i Iridescent Canister	
◆ RST008i See Through Canister	13
◆ RTCO Papper Can	14
◆ RTCO Foil Seals/Liner	15

Preserve the Freshening all the time with our **Breathable Technology**

In today's world of complex formulations, many products are facing the dreaded "caking" issue often present because of the use of standard paper and foil liners.

RTCO was determined to find a solution to this issue, and as a result, we developed and invented the "Breathable Liner". This innovative liner helps keep your product fresh, and helps avoid loss due to transportation via air, or if subjected to adverse climate conditions.

And here's the best part...it's reusable!





Biodegradable



Protecting the environment has become a monumental concern, and it seems the entire world is promoting sustainability and leaving a low carbon footprint. So, as a leading global packaging manufacturer and supplier, the concept and implementation of “reduce, reuse, and recycle” has become a huge concern for us. We put our development team to work, and now we now offer straw fiber, coconut fiber, starch fiber, red pine fiber, and coffee grinds for lids.

RTCO has, and will continue to meet this challenge head on. Developing new and innovative ways to protect our greatest resource.

Scoop Hook



Less,
but Better.



How many times have you found yourself digging into your powder to find the scoop at the bottom of the jar...powder all over your hand, worse yet, your product is now contaminated! These are just a couple of reasons RTCO designed this innovative, clean way to address this problem. Peel the liner back, and your scoop is there waiting for you...easy access!

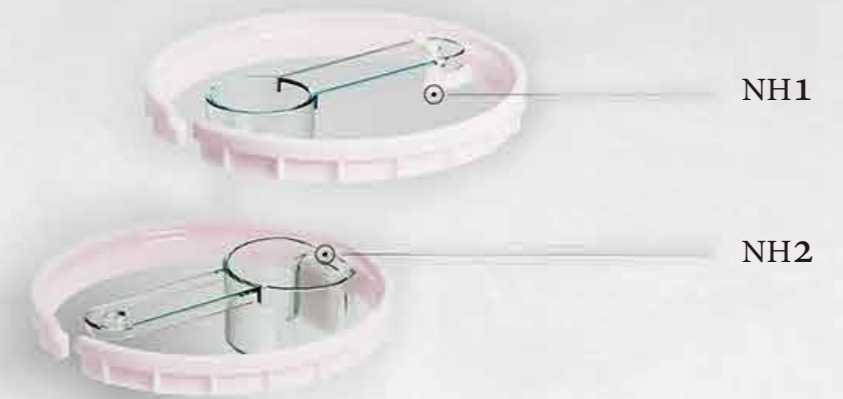

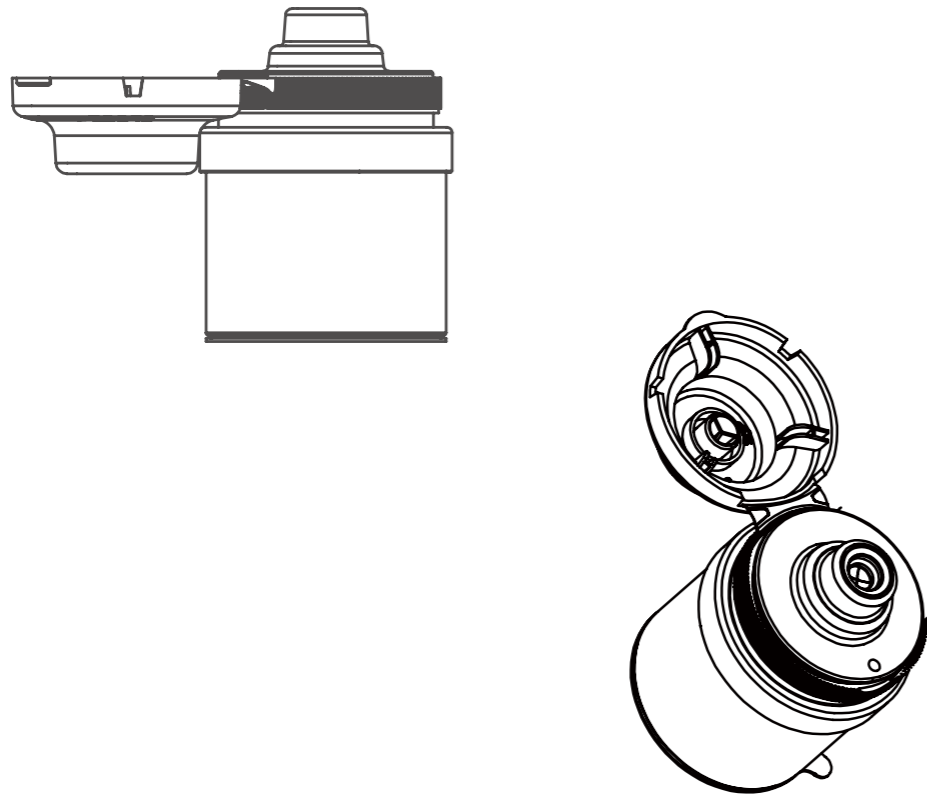

These days, more and more of us want to maintain a healthy body and improve our immunity. RTCO has made it convenient and easy to replenish physical strength and energy anytime, and anywhere! Our **PES (portable energy station)**, provides the best solution. When you are on the go, just find a vending machine or convenience store, buy a bottle of water. With our PES, just replace the cap, twist, shake, and enjoy your energy drink...it's that easy!



The **Soft Touch** coating finish will raise the profile of your products, and separate them from your competitors offerings. The baby soft feel is beautiful and luxurious. Unfortunately, most companies offering this finish, typically see precipitation issues in less than six months. RTCO, by using our patented "SAP" Technology(super anti-precipitation), has solved this problem. The soft touch jar shown, is an example of the high end, distinctive finish RTCO provides, and more importantly, offers a much longer shelf life.

Chrome plating technology has been offered and used in the cosmetic and supplement industries for years. Plating on small parts or components has been very common. Typically, this finish has been done on PP, ABS, and Acrylic. RTCO, after years of trial and error, developed a process to apply this coating to HDPE. Our chrome plating utilizes our patented SGP(Super Grow Plating)technology. This coating will last the life of your product, and maintain the luxurious finish. Additionally, we can offer this chrome finish in any color...we only need a pantone number, and we can make your product stand alone among your competition!



All of RTCO non treated HDPE jars, bottles, and canisters are manufactured with FDA approved, food grade materials. They are produced on fully automatic blow and injection machines, in dust free, clean room environments. RTCO HDPE containers are available in a wide array of colors and sizes. Custom molding is also available, and we excel at creating unique, singular packaging. We also offer a full line of closures...with the option of pressure sensitive, foam retention, induction heat seal, or vented liners. RTCO has what you need, when you need it!

Big Gallon Bottle

All of the RTCO plain large **big gallon bottles** are manufactured with FDA approved food grade materials, and are produced on fully automatic blow and injection machines, in a dust free, closed environment.

RTCO plain big bottles are offered in a variety of colors and sizes. We also offer, and suggest vented lined caps to control moisture, oxygen, and other challenges present in large volume filling.



PP Cap



RTCO also offers our chrome and soft touch finish on these closures, to "**cap** off" your product, and take it to the next level! RTCO has you covered!



Iridescent/See Through Canister

Show the beauty of your product inside, with a silky, sleek veiled coating on the outside.

That is the RTCO secret, beautiful packaging that creates beautiful finished products!

"UPGRADE YOUR BRAND WITH RTCO PACKAGING!"



Paper Can



Green & Fine Packaging
for Your Fine Food

Simple Design
but **More Flexible Use**



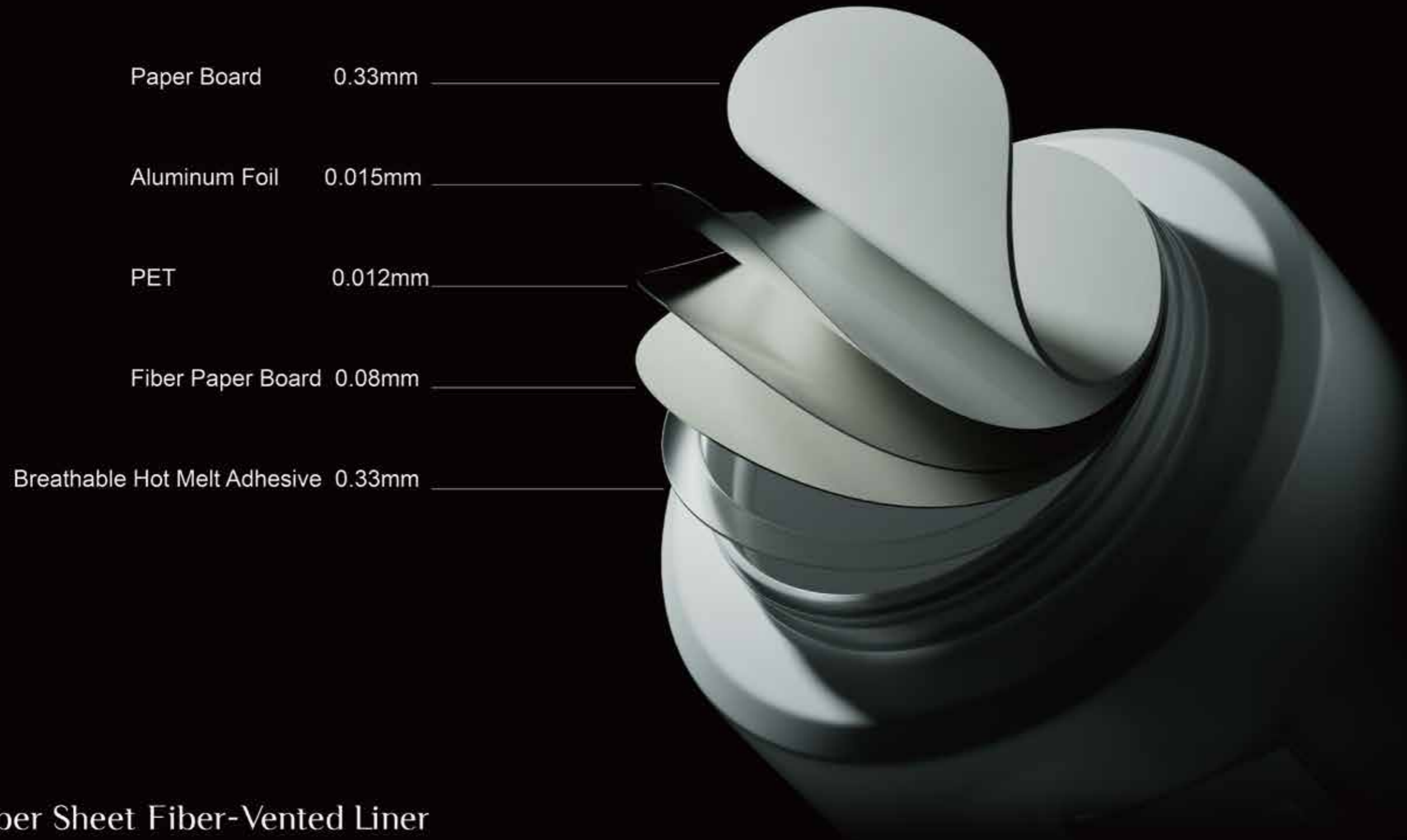

Paper Sheet Fiber-Vented Liner

HDPE BOTTLE

HDPE Bottle						
Resin	Capacity		Height(mm)	Diameter(mm)	Cap size (mm)	Overflow Capacity(ml)
HDPE	2oz	60ml	56	40.0	40	60
HDPE	2.5oz	75ml	59	40.0	40	75
HDPE	4oz	120ml	131.6	40.0	40	140
HDPE	4oz	120ml	85	53.0	53	158
HDPE	6oz	180ml	105	53.0	53	199
HDPE	7oz	207ml	110	53.0	53	205
HDPE	8oz	250ml	91	66.0	63	270
HDPE	8oz	250ml	80	73.4	70	296
HDPE	10oz	300ml	109	65.5	63	329
HDPE	10oz	300ml	95.1	73.4	70	355
HDPE	12oz	360ml	72.5	93.9	T89/BRT89	438
HDPE	13oz	380ml	136	66.0	63	406
HDPE	13oz	380ml	137.2	63.0	C8/63	384
HDPE	15.5oz	475ml	88	88.5	C6/88	472
HDPE	G16oz	480ml	90	93.9	T89/BRT89	537
HDPE	16.5oz	500ml	98.66	94.3	GHO/89	614
HDPE	19oz	557ml	147	73.4	70	622
HDPE	20oz	650ml	124	89.1	89	700
HDPE	G20oz	650ml	112	93.6	T89/BRT89	700
HDPE	24oz	750ml	110	103.5	C100/BRT100	855
HDPE	24oz	750ml	120.5	105.2	GHO/100	931
HDPE	25oz	780ml	150	89.1	89	837
HDPE	28oz	800ml	114.9	102.0	C4/101	855
HDPE	32oz	900ml	130	99.3	C100/BRT100	920
HDPE	G32oz	900ml	130	103.3	C100/BRT100	989
HDPE	33.5oz	950ml	137.83	105.2	GHO/100	1070
HDPE	35oz	1000ml	142	103.5	C100/BRT100	1100
HDPE	40oz	1200ml	159	106.3	C100/BRT100	1140
HDPE	G40oz	1200ml	155	103.3	C100/BRT100	1186
HDPE	41oz	1250ml	141	103.3	100	1150
HDPE	44oz	1300ml	121.9	123.2	120/BRT120	1338
HDPE	46oz	1308ml	176.43	101.3	C100/BRT100	1288
HDPE	50oz	1480ml	158.1	124.5	110	1710
HDPE	55oz	1626ml	149.2	124.1	120/BRT120	1663
HDPE	G55oz	1600ml	148.6	124.3	P120 BGS	1661
HDPE	G60oz	1800ml	152	127.3	123	1800
HDPE	68oz	2000ml	170.4	132.6	H110	2070
HDPE	70oz	2000ml	177	120.8	P120	1972.1
HDPE	G70oz	2000ml	177.5	125.5	120/BRT120	2032
HDPE	100oz	2900ml	236	139.0	P135	3330
HDPE	G100oz	2900ml	250	125.5	C120	2863
HDPE	270oz	7650ml	256	200.0	200	7675
HDPE	18oz	500ml	136	SQ : 66.5	66	517
HDPE	32oz	1100ml	145	SQ : 94.6	93	1126



PET Bottle					
Resin	Capacity	Height(mm)	Diameter(mm)	Cap Size (mm)	Overflow Capacity(ml)
PET	6OZ	105.0	53	53	203
PET	8OZ	81.7	73	70/17	300
PET	8.5OZ	86.0	72	68	305
PET	10OZ	100.0	66	63	330
PET	11OZ	124.5	63.3	62	342
PET	11OZ	103.0	78.4	78	427
PET	13OZ	137.2	63.3	62	385
PET	11OZ	113.9	78.4	78	430
PET	11OZ	124.7	78.4	78	529
PET	14.5OZ	83.6	93.7	T89/BRT89	505
PET	16OZ	96.0	93	89	590
PET	16OZ	95.8	93.7	T89/BRT89	590
PET	19OZ	110.8	93	H89	685
PET	19OZ	132.0	93	93	820
PET	20OZ	106.8	93.7	T89/BRT89	669
PET	24OZ	111.0	105	105	940
PET	25OZ	144.3	93	H89	883
PET	25OZ	136.8	93.7	T89/BRT89	856
PET	32OZ	161.8	93.7	T89/BRT89	1030
PET	32OZ	173.0	95	T89/BRT89	1100
PET	33OZ	167.0	93	89	1060
PET	35OZ	141.0	105	105	1190
PET	50OZ	155.0	126	X110	1710
PET	64OZ	175.0	125.5	H110	1930
PET	68OZ	178.6	141.1	H110	2212
PET	84OZ	170.0	150	P120BG	2600
PET	1.8gal	273.0	208.7	P120BG	7019

PET BOTTLE

Big Gallon Bottle						
Resin	Capacity	Height(mm)	Diameter(mm)	Cap size	Overflow Capacity(ml)	
HDPE	1gallon	3.7L	249	151	120	3895.8
HDPE	1.5gallon	5.6L	257.7	180.9	120	5554
HDPE	1.8gallon	6.8L	273	197	120	7100
HDPE	2gallon	7.5L	290	200	120	7582
HDPE	2.4gallon	9.0L	325	207	120	9372

BIG GALLON BOTTLE

BREATHABLE LINER

Breathable Liner			
Description	Resin	Diameter(mm)	Cap size (mm)
89mm Breathable liner	PC+Silicone	88	BRT89/89mm BRT_H23.2mm/CK100
100mm Breathable liner	PC+Silicone	99.3	BRT100/100mm BRT_H23.2mm
120mm Breathable liner	PC+Silicone	119.7	BRT120

Scoop Hook BOTTLE

Scoop Hook Bottle						
Resin	Capacity		Height(mm)	Diameter(mm)	Cap size (mm)	Filling Capacity(ml)
HDPE	12oz	355ml	81.5	93.7	T89/BRT89	392
HDPE	14oz	414ml	90.5	93.7	T89/BRT89	459
HDPE	16oz	473ml	99.5	93.7	T89/BRT89	529
HDPE	19oz	570ml	123.2	93.7	T89/BRT89	562
HDPE	20oz	591ml	127.7	93.7	T89/BRT89	718
HDPE	25oz	739ml	144	93.7	T89/BRT89	817
HDPE	32oz	946ml	171.7	93.7	T89/BRT89	997
HDPE	G32oz	946ml	148	103.3	GS0 100	930
HDPE	G40oz	1183ml	175	103.3	GS0 100	1150
HDPE	25oz	739ml	122	105.16	C100/BRT100	742
HDPE	33oz	976ml	153	104	C100/BRT100	990
PET	16oz	480ml	99.2	93.7	T89/BRT89	480
PET	20oz	600ml	127.7	93.7	T89/BRT89	660
PET	25oz	750ml	144.9	93.7	T89/BRT89	780

2nd

2nd Generation ScoopHook Bottle						
Resin	Capacity		Height(mm)	Diameter(mm)	Cap size (mm)	Filling Capacity(ml)
HDPE	16oz	581ml	95.00	93.70	NH89/89mm BRT_H23.2mm	490
HDPE	20oz	700ml	113.00	93.70	NH89/89mm BRT_H23.2mm	620
HDPE	34oz	1080ml	139.00	104.00	NH100/100mm BRT_H23.2mm	960
HDPE	25oz	740ml	135.30	93.70	NH89/89mm BRT_H23.2mm	740

Click BOTTLE

Click Bottle						
Resin	Capacity		Heightmm)	Diameter(mm)	Cap size (mm)	Filling Capacity(ml)
HDPE	32oz	960.00	140.00	103.00	CK100	950

Glass Bottle						
Resin	Capacity		Height(mm)	Diameter(mm)	Cap size	Overflow Capacity(ml)
Glass	2oz	60ml	67	43	42	60
Glass	3oz	90ml	62	55	54	90
Glass	4oz	120ml	57	64	62.5	120
Glass	5.4oz	160ml	65	66	66.8	160
Glass	6oz	180ml	76	67	66.8	180
Glass	6oz	180ml	87	64	62.6	180
Glass	7.5oz	225ml	97	63	62.8	225
Glass	8.7oz	260ml	88	73	72	260
Glass	10oz	300ml	94	77	76	300
Glass	12oz	360ml	89	84	83	360
Glass	12oz	360ml	110	75	74	360
Glass	14oz	420ml	86	93	92.5	420
Glass	17.2oz	510ml	127	82	81	510

Glass BOTTLE

SCOOP

Scoop				
Capacity	Resin	Outer Diameter (mm)	Height (mm)	Length (mm)
3cc	PP	30.36	8.50	70.93
4cc	PP	23.00	13.00	75.00
5cc	PP	23.00	16.00	75.00
5cc	PP	25.50	13.50	70.00
6.5cc	PP	27.02	17.27	70.95
7cc	PP	29.00	10.00	125.00
9cc	PP	29.89	15.47	77.58
9cc	PP	29.00	15.00	77.00
9cc	PP	29.00	17.34	81.00
10cc	PP	29.75	19.28	91.80
10cc	PP	29.00	17.00	77.00
C10cc	PP	IN 26	25.00	70.00
10cc	PP	34.12	20.00	69.98
20cc	PP	42.53	23.00	79.99
11cc	PP	30.00	19.00	78.00
11cc	PP	30.30	19.00	79.00
13cc	PP	29.00	23.00	78.00
14.5cc	PP	32.91	23.50	102.50
14.79cc	PP	35.00	19.00	69.00
14.79cc	PP	35.00	19.00	113.00
15cc	PP	37.50	41.50	94.00
C16cc	PP	30.00	36.00	110.00
18cc	PP	35.48	22.93	69.43
20cc	PP	35.00	24.00	118.00
20cc	PP	42.30	18.90	102.60
23cc	PP	35.00	28.00	84.00
24.5cc	PP	38.20	20.50	174.00
25cc	PP	44.30	47.50	110.94
26.5cc	PP	35.00	33.00	118.00
35cc	PP	39.00	32.00	82.00
60cc	PP	46.40	40.61	84.74
60cc	PP	50.00	36.00	120.50
63cc	PP	46.00	43.00	97.00
80cc	PP	46.46	55.66	84.78
90cc	PP	57.02	39.87	88.54
95cc	PP	57.70	44.70	121.39
4oz	PP	55.35	53.12	88.24
6oz	PP	62.20	63.70	94.70

CAP

Cap			
Description	Resin	Diameter(mm)	Height (mm)
24mm Caps	PP	24.00	21.8
28mm Caps	PP	28.00	17.9
38mm Caps	PP	38.00	12
38/400mm Caps	PP	38.00	11.4
NC/38/400mm Caps	PP	38.00	34.6
40mm Caps	PP	40.00	13.5
43mm Caps	PP	43.00	
45/400mm Caps	PP	45.00	11.4
53mm Caps	PP	53.00	18.6
53/400mm Caps	PP	53.00	11.4
62mm Caps	PP	62.00	13.5
63mm Caps	PP	63.00	18.6
66mm Caps	PP	66.00	18.6
68mm Caps	PP	68.00	20
70mm Caps	PP	70.00	12
15.3/70mm Caps	PP	70.00	12
17/70mm Caps	PP	70.00	17
18.6/70mm Caps	PP	70.00	18.6
84.5mm Caps	PP	84.50	15.6
89mm Caps	PP	89.00	14.5
89mm Caps	PP	89.00	15.5
89mm Caps	PP	89.00	20.32
89mm Caps	PP	89.00	19.4
C100mm Caps	PP	100.00	18.66
P100mm Caps	PP	100.00	16
100mm Caps	PP	100.00	21.1
110mm PowderCaps	PP	110.00	22.5
110mm PowderCaps	PP	110.00	23
110mm TPR Caps	PP	110.00	16.6
C120mm PowderCaps	PP	120.00	24.4
P120mm PowderCaps	PP	120.00	23
P120mm PowderCaps	PP	120.00	26
120mm PowderCaps	PP	120.00	24.45
125mm Caps	PP	125.00	18.3
P135mm PowderCaps	PP	135.00	24.5
165mm PowderCaps	PP	165.00	24.5
200mm PowderCaps	PP	200.00	38.8
66mm SquareCaps	PP	66.00	18.6
93mm SquareCaps	PP	93.00	16.7
62mm TPR Caps	PP+TPR	62.00	31.5
90mm TPR Caps	PP+TPR	90.00	31.5
100mm TPR Caps	PP+TPR	100.00	31.5
NH89mm Caps	PP	93.10	21
NH100mm Caps	PP	103.50	21
CK100mm Caps	PP	102.50	20
89mm BRT_H23.2mm Caps	PP	93.10	23
100mm BRT_H23.2mm Caps	PP	103.50	23

R&D Center

Design projects: >800 cases/year
Succeed projects: >8000 cases
Global patent and brands: 100



OUR TEAM

RTCO has an impressive, highly trained and qualified research and development team. We are always looking to find and develop the next innovation and creative new exciting packaging components. Searching for the latest and newest sustainable options, jar and cap designs, and high end finishes to offer our worldwide customer base the best and newest technology.

At RTCO, it is our commitment to offer the most responsive customer service, and we are always available for technical support...around the clock.

The RTCO R&D team is ever expanding...adding new highly trained talent. Our main focus is three fold: Environmentally Friendly, User Friendly, and Custom Friendly.



OUR FACTORY

Professional
Equipment

Automated
Pipeline

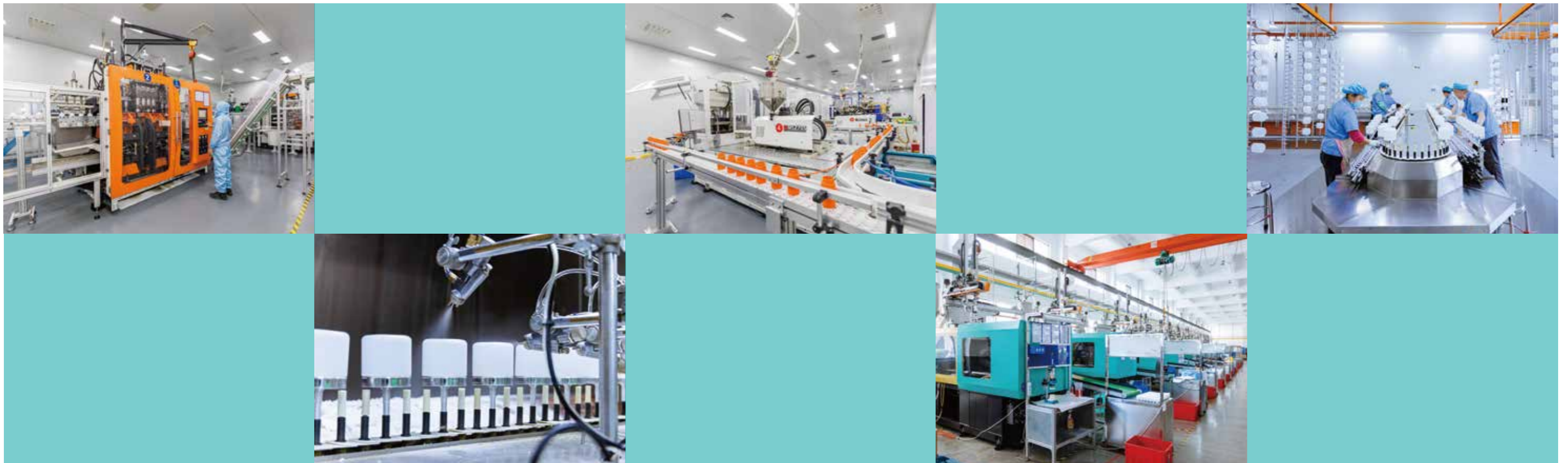

RTCO has multiple manufacturing facilities in Shanghai and Zhejiang. With over 120 injection machines, 20 blow molding machines, 30 printing lines, four out-coating lines, and more than 15 assembly lines.

Add to that, the literal thousands of mold sets...so there's a great chance we have what you are looking for. And if we don't have it, we will build it for you!

All of these advantages support RTCO's "Three-One" strategy. Our R&D team can produce a 3D sample in as little as one day. Once the prototype is approved, our experienced tooling department can make a production tool in a month. RTCO can then produce a trial order in a week...giving you a jump on the competition, and giving you the fastest path to market!

NORTH AMERICA SALES AND WAREHOUSE LOCATION ”



Currently, RTCO has a warehouse location in the Savannah Georgia area. In early 2024, we will open our US sales office and stocking warehouse. This will enable RTCO to become a true "Just In Time" packaging source. We will be able to respond and ship many items within 24 hours. Your "One Stop Source!"



US GA warehouse:

88 CLYDE ALEXANDER
WAY, POOLER GA 31322

EUR warehouse:

Vlaardingweg 62 3044 CK
Rotterdam The Netherlands

